



江苏海基新能源股份有限公司

Jiangsu Hige Energy CO., Ltd

磷酸铁锂电池规格书

LFP/AG CELL SPECIFICATIONS

产品型号 MODEL NO. LFP71173205E-280Ah

制作日期 DATE: 2023-02-27

客户物料编码 Customer Part No. _____

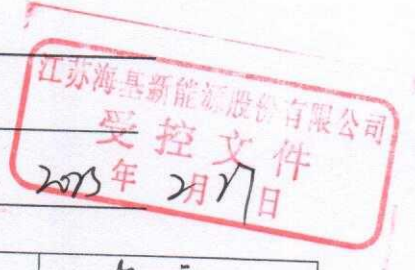

规格书审批项 Approved	编制 Hige Prepared By	徐亮
	审核 Hige Checked By	王纪胜
	批准 Hige Approved By	葛科
	客户确认 Customer Checked By	
	请签名盖章确认后回传我司 Please signed and returned one copy to Hige.	

Address (地址): 中国·江苏省江阴市云亭镇建设路 55 号
 No.55, Jianshe Road, Yunting Town, Jiangyin City, Jiangsu Province, China
 Postcode(邮编): 214400
 Website (网址): <http://www.ihige.com>
 Tel(电话): (+86-0510)88012005
 Fax(传真): (+86-0510)88012020

目录 Catalogue

目录 Catalogue	1
更新记录 Updating record.....	2
客户要求 Custom requirement	3
术语定义 Term definitions	4
1. 适用范围 Scope.....	6
2. 产品说明 Product instruction	6
3. 外观 Appearance	6
4. 产品性能指标 Product performance	6
4.1 电芯基本参数 Cell specifications	6
4.2 电池性能 Cell Performance.....	6
5. 产品寿命终止管理 Product life ending manage.....	8
6. 应用条件 Application conditions	8
7. 安全防范 Safety precautions	10
8. 免责声明 Disclaimer	11
9. 风险警告 Risk warnings	12
10. 电芯示意图 Cell drawings.....	13

江苏海基新能源股份有限公司
受控文件
2023年2月17日

HIGEE 海基	PRODUCT SPECIFICATION	DOC NO : <u>BSLFP71173205E-280Ah</u>
		REV. : <u>A/03</u>
		SHEET : <u>3</u> of <u>13</u>

客户要求 Custom requirement

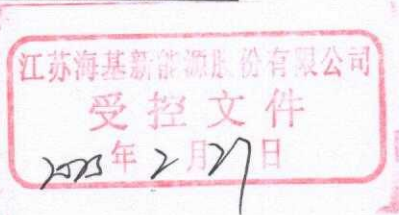

型号 Model: LFP71173205E-280Ah

版本 Version: 1.0

要求客户写出他们的需求信息并提前与海基沟通。如果客户有一些特别的应用或者操作条件不同于此文件中所描述的，海基可以根据客户的特别要求进行产品的设计和生产。

It is necessary to ask customs to provide their requirements and keep communication with Higeer. If there are some special applications or something different from those described in the specification in use, we could design and manufacture the product according to customer's special requirements.

No	特殊要求 Special requirements	标准 Standard
1		
2		
3		
4		
5		

客户代码 Custom code : _____ 签字 Signature: _____ 日期 Date: _____

	PRODUCT SPECIFICATION	DOC NO : <u>BSLFP71173205E-280Ah</u>
		REV. : <u>A/03</u>
		SHEET : <u>4</u> of <u>13</u>

术语定义 Term definitions

江苏海基新能源有限公司
 受控文件
 2021年 2月 1日

术语 Term	定义 Definition
产品 Product	本规格书中的“产品”是指海基生产的 280Ah、3.2V 可充电磷酸铁锂动力电池。 This product specification is just applied to the 3.2V/280Ah secondary LFP cell produced by Jiangsu Hige Energy Co., Ltd.
客户 Custom	指《海基产品销售合同》中的买方。 The buyer in the sale contract.
海基 Hige	指《海基产品销售合同》中的卖方 The seller in the sale contract.
环境温度 Ambient temperature	电池所处的周围环境温度。 The temperature of the air surrounding a cell.
电池管理系统 Battery manager system	客户用于监测和记录产品在整个服务期限内的运行参数的一种有效的追踪和控制系统。其追踪和记录的参数包括但不限于电压、电流、温度等，以控制产品的运行并确保产品运行环境及运行条件符合本规格书的规定。 A tracking and controlling device integrating with hardware and software, which is used to monitor and record operating data in battery service life. The parameters consist of voltage, current, temperature and so on. The device can control the operating state of battery and keep the working surrounding and condition meeting the requirements of this specification.
电芯温度 Cell temperature	由接入电池的温度传感器测量的电芯的温度。 Surface temperature of a cell measured by temperature sensor.
新电池状态 Fresh cell status	指电池下线日期开始算起 7 天范围内的状态。 Within 7 days after being off-line.
充电倍率 C-Rate	充电电流与电池标额定容量值的比值。 The ratio of charge current to rated capacity.
循环 Cycle	电池按规定的充放电制度充放一次为一个循环。 One sequence of charge and discharge as prescribed.
生产日期 Manufacture date	电池的制造日期。每个电池的顶盖激光打码处标识了明确的制造日期。 The date when the cell was manufactured, which is clearly printed by laser on the top cap.
开路电压 Open-current voltage	没有接入任何负载和电路时测得的电池的电压。 The voltage between the battery terminals with no load applied.
初始容量 Initial capacity	按照本规格书所列的标准充放电条件所测得的容量，循环 3 次，取 3 次测量值的最大值。 The capacity measured according to the standard charge and discharge procedure listed in this specification. The cell should be cycled 3 times, and select the maximum value as the initial capacity.
可恢复容量 Recoverable capacity	电池储存后，按照本规格书所列的标准充放电条件所测得的容量，循环 3 次，取 3 次测量值的最大值。 The capacity measured according to the standard charge and discharge procedure listed in this specification after the cell is stored for a period of time. The cell should be cycled 3 times, and select the maximum value as the recoverable capacity.

HIGEE 海基

PRODUCT
SPECIFICATION

DOC NO : BSLFP71173205E-280Ah

REV. : A/03

SHEET : 5 of 13

供货协议 Supplier agreement	海基和客户共同签订的有关本规格书产品的交易条款。 The terms of the transaction between Higeer and the customer regarding the products of this specification.
标准充电 Standard charge	25±2 °C, 0.5C 恒流持续充电至最大电压 3.65V, 然后在 3.65V 下恒压持续充电直至电流下限 14A。 A cell shall be charged at a constant current of 0.5 C to 3.65V at first, and then charged at a constant voltage of 3.65V until the current reduces to 14A.
标准放电 Standard discharge	25 ± 2 °C, 标准充电后, 以 0.5C 恒流放电至 2.5V Discharging the cell to 2.5V at 0.5C after standard charging at 25 ± 2 °C.
荷电状态 (SOC) State of charge	任意状态下, 电池荷电量与电池最大荷电能力的比值。如: 若将容量为 280Ah 的状态视为 100% SOC, 则容量为 0Ah 时, SOC 为 0%。 An expression of the present battery capacity as a percentage of maximum capacity. For example, if the SOC is defined as 100% when the remaining capacity is 280Ah, the state of 0Ah is regarded as 0% SOC.
温升 Temperature rising	规格书规定的条件下, 充电或者放电前后电芯表面温度差。 The surface temperature difference between the cells before and after charging or discharging.
测量单位 Measurement unit	“V” (Volt) 伏特 (V), 电压单位 voltage unit “A” (Ampere) 安培 (A), 电流单位 current unit “Ah” (Ampere-hour) 安培-小时 (Ah), 容量单位 capacity unit “Wh” (Watt-hour) 瓦特-小时 (Wh), 能量单位 energy unit “Ω” (Ohm) 欧姆 (Ω), 电阻单位 resistance unit “mΩ” (milliohm) 毫欧 (mΩ), 电阻单位 resistance unit “°C” (degree Celsius) 摄氏度 (°C), 温度单位 temperature unit “mm” (millimeter) 毫米 (mm), 长度单位 length unit “s” (second) 秒 (s), 时间单位 time unit “Hz” (Hertz) 赫兹 (Hz), 频率单位 frequency unit

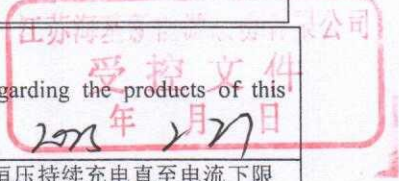

HIGEE 海基	PRODUCT SPECIFICATION	DOC NO : BSLFP71173205E-280Ah
		REV. : A/03
		SHEET : 6 of 13

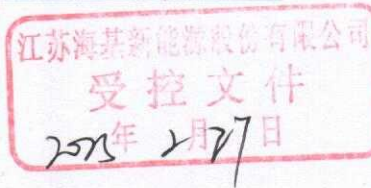

1. 适用范围 Scope

本规格书适用于江苏海基新能源股份有限公司生产的磷酸铁锂电池。

This specification is just applied to the LFP cell produced by Jiangsu Hige Energy Co., Ltd.

2. 产品说明 Product instruction

条目 Item	内容 Content	备注 Notes
产品型号 Product model	LFP71173205E-280Ah	
产品状态 Product status	量产 Mass production	

3. 外观 Appearance

电池/电池组外观无破裂、划痕、变形、生锈、污迹、电解液泄漏等不良现象。

The cell/battery shall be free from cracks, scars, breakage, rust, discoloration, leakage or deformation.

4. 产品性能指标 Product performance

4.1 电芯基本参数 Cell specifications

序号 No.	项目 Item	规格 Specification	条件 Condition
1	额定容量 Rated capacity	280 Ah	
2	标称电压 Nominal voltage	3.2 V	
3	电池内阻 (1kHz) AC impedance	≤0.18mΩ	电芯出货日起 7 天内 (额定容量的 40% SOC) Testing within 7 days after shipment (40% SOC)
4	电池重量 Cell weight	≤5.5 kg	
5	标准充电电流 Standard charge current	0.5 C	25±2 °C
6	最大持续充电电流 Maximum sustainable charging current	1 C	25±2 °C
7	标准放电电流 Standard discharge current	0.5 C	25±2 °C
8	最大持续放电电流 Maximum sustainable discharging current	1 C	25±2 °C
9	最大脉冲放电电流 Peak pulse discharge current	3C	25±2 °C, 50% SOC, 30 s
10	工作电压 Operating voltage	2.5~3.65 V	T>0 °C
		2.0~3.65 V	T≤0 °C
11	工作温度 Operating temperature	0~50 °C	充电 Charge
		-20~55 °C	放电 Discharge
		-30~45 °C	贮存 Store
12	月自放电	≤3.0%/月	出货 3 个月后电芯, 40%SOC, 25±2°C 储存
13	电芯尺寸 Cell dimension	参照第 10 节 Refer to Section 10	
14	包膜绝缘耐压测试 Voltage tolerance test for dielectric film	0~15 mA	AC2800±5V, 压力 800±20Kg (AC 2800 ± 5 V, pressure 800 ± 20 kg)

4.2 电池性能 Cell Performance

4.2.1 除非其它规定, 测试应在到货之日起 1 个月内进行, 并且符合以下测试条件:

Unless otherwise stated, tests should be carried out within one month of delivery under the following conditions:

	PRODUCT	DOC NO : BSLFP71173205E-280Ah
	SPECIFICATION	REV. : A/03
		SHEET : 7 of 13

相对湿度 Relative humidity: 65±20%

环境温度 Ambient Temperature: 25±2 °C

大气压力 Barometric pressure: 86~106 kPa

4.2.2 电性能

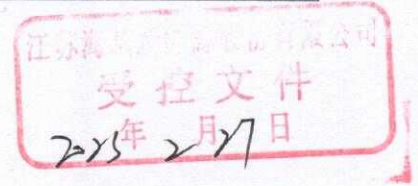

序号 No.	项目 Item	规格 Specification	测试方法 Test method
1	初始放电容量 Initial discharging capacity	0.5C(A)容量≥额定容量 0.5C (A) capacity ≥ rated capacity	新电池状态, 电池标准充电后, 搁置 30 分钟, 进行标准放电, 循环三次, 取 3 次测量值的最大值。 Fresh cell, after a standard charge procedure, a cell is allowed to rest for 30 min, then follows by a standard discharge procedure. This cycle is repeated three times and take the maximum of 3 measurements.
2	最大持续充电电流 Maximum continuous charge current	1C	25±2 °C, 1C 恒流持续充电至最大电压 3.65V, 然后在 3.65V 下恒压持续充电直至电流下限≤14A。 A cell shall be charged at a constant current of 1C to 3.65V at first, and then charged at a constant voltage of 3.65V until the current reduces to 14A.
3	最大持续放电电流 Maximum continuous discharge current	1C	电池标准充电后, 以 1C(A)电流放电至 2.5V。 After a standard charge procedure, a cell is discharged at 1C(A) to 2.5V.
4	脉冲放电电流 Peak pulse discharge current	3C, 30 s	电池标准充电后, 以 0.5C(A)电流放电至 50%SOC, 静置 30 分钟, 以最大脉冲电流放电, 电压 2.5V 或者放电达到持续时间时截止。 After a standard charge procedure, a cell is discharged to 50% SOC at 0.5C(A) and allowed to rest for 30 min, then discharged at the maximum pulse current until its voltage reach 2.5V or the discharge time reach the deadline.
5	循环寿命 Cycle life	循环寿命≥6000 次 Cycle count≥6000	新电池状态, 标准充放电模式, 残余容量≥额定容量×80% Fresh cell, standard charge/discharge procedure, residual capacity ≥ rated capacity ×80%
6	荷电保持能力 Charge Retention	剩余容量≥初始容量×95% 恢复容量≥初始容量×96% Residual capacity ≥ initial capacity×95% Recoverable capacity ≥ initial capacity×96%	电池标准充电后, 在环境温度 25±2 °C 条件下搁置 28 天, 以标准放电方式放电测量电池容量。然后再以标准充放电方式测量电池恢复容量。 After a standard charge procedure, a cell is stored for 28 days at 25 ± 2 °C, then a standard discharge procedure is carried out to measure the capacity. The recoverable capacity is measured by the standard charge-discharge procedure.
		剩余容量≥初始容量×94% 恢复容量≥初始容量×95% Residual capacity ≥ initial capacity×94% Recoverable capacity ≥ initial capacity×95%	电池标准充电后, 在环境温度 55±2 °C 条件下搁置 7 天, 以标准放电方式放电测量电池容量。然后再以标准充放电方式测量电池恢复容量。 After a standard charge procedure, a cell is stored for 7 days at 55 ± 2 °C, then a standard discharge procedure is carried out to measure the capacity. The recoverable capacity is measured by the standard charge-discharge procedure.
7	高温性能 High temperature	容量≥初始容量×95% Capacity ≥ initial capacity×95%	新电池状态, 电池标准充电后, 在温度 55±2 °C 的高温箱中放置 5h, 然后以标准放电方式放电测量电池容量。 Fresh cell, after a standard charge procedure, a cell is stored in a temperature chamber for 5 h at 55 ± 2 °C. A standard discharge procedure is carried out to measure the capacity.
8	低温性能 Low temperature	容量≥初始容量×70% Capacity ≥ initial capacity×70%	新电池状态, 电池标准充电后, 在温度-20±2 °C 的高温箱中放置 24h, 然后以标准放电方式放电测量电池容量。 Fresh cell, after a standard charge procedure, a cell is stored in a temperature chamber for 24 h at -20 ± 2 °C. A standard discharge procedure is carried out to measure the capacity.

HIGEE 海基	PRODUCT SPECIFICATION	DOC NO : BSLFP71173205E-280Ah
		REV. : A/03
		SHEET : 8 of 13

江苏海基新能源有限公司
受控文件
2021年2月27日

4.2.3 安全与可靠性 Safety performance

序号 No.	项目 Item	标准 Standard	测试方法 Testing method
1	过充测试 Over-charge performance	不爆炸、不起火 No explosion or fire	参照 GB/T36276-2018 Reference to GB/T36276-2018
2	过放测试 Over-discharge performance	不爆炸、不起火 No explosion or fire	参照 GB/T36276-2018 Reference to GB/T36276-2018
3	短路测试 Short-circuit performance	不爆炸、不起火 No explosion or fire	参照 GB/T36276-2018 Reference to GB/T36276-2018
4	跌落测试 Drop test	不爆炸、不起火 No explosion or fire	参照 GB/T36276-2018 Reference to GB/T36276-2018
5	加热测试 Heating Test	不爆炸、不起火 No explosion or fire	参照 GB/T36276-2018 Reference to GB/T36276-2018
6	挤压测试 Crush Test	不爆炸、不起火 No explosion or fire	参照 GB/T36276-2018 Reference to GB/T36276-2018
7	热失控测试 Thermal runaway test	不爆炸、不起火 No explosion or fire	参照 GB/T36276-2018 Reference to GB/T36276-2018
8	低气压测试 Low pressure test	不爆炸、不起火 No explosion or fire	参照 GB/T36276-2018 Reference to GB/T36276-2018
9	海水浸泡测试 Seawater immersion test	不爆炸、不起火 No explosion or fire	参照 GB/T31485-2015 Reference to GB/T31485-2015
10	针刺测试 Nail test	不爆炸、不起火 No explosion or fire	参照 GB/T31485-2015 Reference to GB/T31485-2015
11	温度循环测试 Temperature cycle test	不爆炸、不起火 No explosion or fire	参照 GB/T31485-2015 Reference to GB/T31485-2015

5. 产品寿命终止管理 Product life ending manage

电池的使用期限是有限的。客户应该建立有效的跟踪系统监测并记录每个使用期限内电池的内阻和容量。内阻及容量的测量方法和计算方法需要客户和海基共同讨论和双方同意。当使用中的电池的内阻超过这个电池最初内阻的150%或容量小于等于70%（196 Ah, 25 °C）时，应停止使用电池。违反该项要求，将免除海基依据产品销售协议以及本规格书所应承担的产品质量保证责任。

The life of a battery is limited. The users should establish an effective tracking system to monitor and record the internal impedance and capacity of each battery over its lifetime. The user must establish an effective monitoring system and record the capacity and impedance of every battery in working. The measurement method and calculation method of internal impedance and capacity should be confirmed by Higeer and customer together.

A battery should be stopped from using once its AC impedance is more than 150% initial value or the capacity is less than 70% rated value (196Ah, 25 °C). Otherwise, Higeer will not be responsible for any relevant liabilities.

6. 应用条件 Application conditions

客户应当确保严格遵守以下与电池相关的应用条件：

The users should not violate the following application conditions:

6.1 客户应配置电池管理系统，严密监控、管理与保护每个电池。

The users should equip BMS to monitor, manage and protect each battery.

6.2 客户应保存完整的电池运转的监测数据，用作产品质量责任划分的参考。不具备完整的电池系统使用期限内的监测数据的，海基不承担产品质量保证责任。

	PRODUCT SPECIFICATION	DOC NO : <u>BSLFP71173205E-280Ah</u>
		REV. : <u>A/03</u>
		SHEET : <u>9</u> of <u>13</u>

It is necessary for the users to record and reserve complete operation data of battery as a reference for the division of product quality responsibility. If there is a lack of the monitoring data, Higeer will not be responsible for any relevant liabilities.

6.3 电池管理系统需满足以下最基本的检测和控制要求:

BMS should meet the following basic test and control requirements:

No.	项目 Item	参数 Parameter	保护动作 Protecting action
6.3.1	充电终止电压 Charge termination voltage	3.65 V	当电池的电压达到 3.65V 时终止充电 Stopping charging when the voltage is up to 3.65V.
6.3.2	上限充电电压 Upper limit charging voltage	3.70V	当电池电压达到 3.7V, 锁定电池管理系统直到技术人员解决问题。 Locking BMS until the engineer solves the problem when the voltage is up to 3.70V
6.3.3	放电终止电压 Discharge termination voltage	2.5 V	终止放电当电池的电压到达 2.5V, 停止放电 Stopping discharging when the voltage is less than 2.5V.
6.3.4	下限放电电压 Lower limit discharging voltage	2.0V	当电池的电压达到 2.0V 时, 锁定电池管理系统直到技术人员解决问题 Locking BMS until the engineer solves the problem when the voltage is less than 2.0V.
6.3.5	短路保护 Short-circuit protection	NA	发生短路时, 由熔断器断开电池(电路) Turning-off the current by fuse when the cell short-circuit.
6.3.6	过流保护 Over-current protection	NA	电池管理系统控制放电电流符合规格 BMS adjusts the discharging current according to specification.
6.3.7	过热保护 Overheat protection	NA	当温度超过本规格书规定时, 终止充电/放电 Terminating charging or discharging when temperature exceeds the value in this specification.
6.3.8	充电时间过长保护 Charging timeout protection	充电时间在 8 小时内 No more than 8 hours	充电时间长于 8 小时, 则终止充电 Terminating charging when charging time is over 8h.

备注: 以上 No.6.3.2、6.3.4 为警示条款, 提请客户注意: 当电池达到上述任何一项条款描述的指标和参数状态时, 意味着电池已超出本规格书规定的使用条件, 客户需依“保护动作”及本规格书其它相关规定对电池采取保护措施, 同时, 海基声明对上述使用状态的电池质量不承担任何保证责任, 并对因此而导致的客户及第三方的任何损失不予赔偿。

Notes: The above No. 6.3.2, 6.3.4 are warning clauses, to which the customers should pay more attention. Once a battery reaches the specifications and parameter status described in any of the above terms, it means that the battery has exceeded this specification. The customers shall protect the battery according to the “protection action” and other relevant provisions of this specification. At the same time, Higeer declares no responsibility for the quality of the battery in the above-mentioned state of use, and will not be liable for any loss caused by the customers and third parties.

6.4 若预计将电池存放 30 天以上的, 应将 SOC 调整为 40%左右; 长时间存放时, 应每 3 个月进行标准充放电一次, 然后将 SOC 调整为 40%左右。

If the cell is expected to be stored for more than 30 days, its SOC should be adjusted to about 40%. For long-term storage, the standard charge and discharge should be performed every 3 months, and the SOC should be adjusted to about 40%.

6.5 电池避免在本规格书禁止的低温条件下充电 (包括标准充电, 脉冲充电), 否则可能出现意外的容量降低现象。另一方面, 电池管理系统应依照最小的充电和再生充电温度进行控制, 否则, 海基不承担质量保证责任。

A battery should not be charged at a low temperature prohibited by this specification (including standard charging, peak pulse charging), otherwise the capacity will be unexpectedly reduced. On the other hand, BMS should operate in accordance

	PRODUCT SPECIFICATION	DOC NO : <u>BSLFP71173205E-280Ah</u>
		REV. : <u>A/03</u>
		SHEET : <u>10</u> of <u>13</u>

with the minimum charging and regenerative charging temperature. Otherwise, Higeer will not be responsible for quality assurance.

6.6 电箱设计中应充分考虑电芯的散热、防水、防尘问题，电箱必须满足国家有关标准规定的防水、防尘等级。由于防水、防尘问题而导致的电芯或电池的损坏（如腐蚀、生锈等），海基不承担质量保证责任。

Heat dissipation, waterproof, dustproof and other issue should be fully considered in the design of the pack case to meet the relevant national standards. Otherwise, Higeer will not be responsible for any resulting damages.

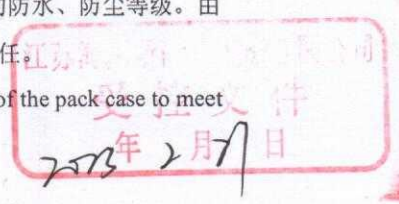

7. 安全防范 Safety precautions

7.1 禁止将电池浸入水中。

Do not immerse the battery in water.

7.2 禁止将电池投入火中或长时间暴露在超过本规格书规定的温度条件的高温环境中，否则可能会导致火灾。在任何正常的使用情况下，电芯温度不能超过 60 °C，如果电池中电芯温度超过 60 °C，电池管理系统需关闭电池，停止电池运行。

It is forbidden to throw the battery into fire or expose it to high temperature environment exceeding the temperature conditions specified in this specification for a long time, otherwise it may cause a fire. In any normal use, a cell temperature should not exceed 60 °C. Otherwise, BMS should turn off the circuit and stop the cell from operating.

7.3 禁止电池正负极短路，否则强电流和高温可能导致人身伤害或者火灾。在电池系统组装和连接时，应有足够的安全保护，以避免短路。

Do not short circuit a cell, otherwise strong current and high temperature may cause personal injury or fire. When the battery system is assembled and connected, there should be sufficient safety protection to avoid short circuits.

7.4 严格按照标示和说明连接电池正负极，禁止反向充电。

Connect the positive and negative terminals of a cell in strict accordance with the instructions. Reverse charging is prohibited.

7.5 禁止电池过充，否则，可能引起电池过热和火灾事故的发生。在电池安装和使用中，硬件和软件需实行多重过充失效安全保护。

Do not overcharge. Otherwise, it may cause overheating and fire accidents. Hardware and software are required for multiple overcharge fail-safe protection in battery installation and use.

7.6 根据本规格书标准充电后，应结束正常充电。当持续充电时间超过合理的时间限制，电池会出现过热现象，可能会引起热失控和火灾。

Stop normal charge after the standard charge procedure described in the specification. When the continuous charging time exceeds a reasonable time limit, the battery may overheat, leading to thermal runaway and fire.

7.7 客户应将电池安全地固定在固体平面上，并将电源线安全地束缚在合适的位置，以避免摩擦而引起电弧和火花。

A cell should be fixed on a solid board and the power wires should be installed in place to avoid arcs and sparks caused by friction.

7.8 当电解液泄露时，应避免皮肤和眼睛接触电解液。如有接触，应使用大量的清水清洗接触到的区域并向医生寻求帮助。禁止任何人或动物吞食电池的任何部件或电池所含物质。

When the electrolyte leaks, the skin or eyes should not contact with the electrolyte directly. If it does happen, please wash with clean water and go to see a doctor immediately. It is forbidden to eat any part of the cell or any material contained in the cell.

7.9 尽力保护电池，使其免受机械震动、碰撞及压力冲击，否则电池内部可能短路，产生高温和火灾。

Try to protect the battery from mechanical shock, impact and pressure shocks, otherwise the battery may be short-circuited inside, causing high temperatures and fires.

	PRODUCT SPECIFICATION	DOC NO : <u>BSLFP71173205E-280Ah</u>
		REV. : <u>A/03</u>
		SHEET : <u>11</u> of <u>13</u>

7.10 电池充电过程中可能发生不适当的终止充电现象。如：超出允许的充电时间充电，充电电压过高而终止充电或充电电流过强而终止充电。上述现象被定义为“非正常的终止充电”。当发生上现象时，可能意味着电池系统出现漏电或某些部件出现故障。在没有找到根本原因并彻底解决之前不能继续对该电池充电。当发生以上现象时，电池管理系统应该通过自动锁定功能，禁止后续的充电，并提醒使用者将装载有该电池的交通工具退回到经销商处进行系统维护。

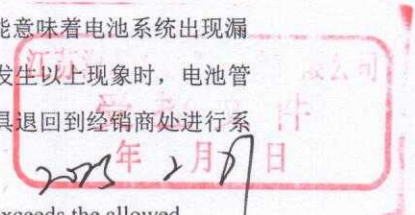

Abnormal termination of charging may occur during battery charging, such as charging that exceeds the allowed charging time, charging voltage is too high, or charging current is too strong to terminate charging. The above phenomenon is defined as "abnormal termination of charging", which suggests that the battery system may be leaking or some components may malfunction. The battery should not be charged until the root cause is found and completely resolved. When the above phenomenon occurs, BMS should disable the subsequent charging through the automatic locking function, and remind the user to return the vehicle loaded with the battery to the dealer for system maintenance.

7.11 本规格书第 4 条描述的测试实验时，如操作不当可能会引起电池起火或者爆炸。该测试实验只能由配备适当的防护装备的专业人员在专业的实验室进行。否则，可能会导致严重的人身伤害和财产损失。

When performing the test described in Section 4 of this specification, improper operation may cause the battery to catch fire or explode. This test can only be carried out in a professional laboratory by professionals with appropriate protective equipment. Failure to do so may result in serious personal injury and property damage.

8. 免责声明 Disclaimer

8.1 如果产品需求单位不按本说明书中的规定进行使用，如果电芯出现任何问题，所有责任由产品需求单位承担，海基将不承担任何责任。

If the battery is in trouble because the buyers do not use the product in accordance with the provisions of this specification and, all responsibility shall be borne by the buyers, and Higeer will not assume any responsibility.

8.2 如果由于产品需求单位不按本说明书中的规定进行使用，造成社会性影响，并对海基的声誉造成影响的，海基将会追究产品需求单位的责任。根据对海基造成的影响程度，产品需求单位需向海基提供赔偿。

If the buyers do not use the product in accordance with the provisions of this specification, resulting in social impact, and damage to the reputation of Higeer, Higeer will hold the responsibility of the buyers. The buyers should provide compensation to Higeer according to the adverse effects on Higeer.

9. 风险警告 Risk warnings

9.1 警示声明 Warning statements

警告 Warning

电池存在潜在的危险，在操作和维护时必须采取适当的防护措施！

The battery is potentially dangerous and must be properly guarded during operation and maintenance!

不正确地操作本规格书所描述的测试实验，可能导致严重的人身伤害和财产损失！

必须使用正确的工具和防护装备操作电池。

Improper operation of the test described in this specification may result in serious personal injury and property damage!

The battery must be operated with the correct tools and protective equipment.

电池的维护必须由具有电池专业知识并经过安全培训的人士执行。

Battery maintenance must be performed by a professional with battery expertise and safety training.

不遵守上述警告可能造成多种灾难。

Failure to follow these warnings may result in multiple accidents.

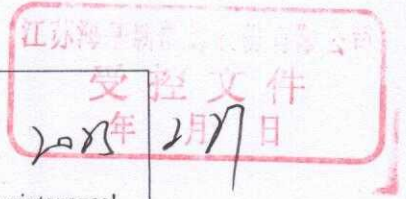

9.2 危险类型 Danger types

客户知悉在电池使用和操作过程中存在以下潜在的危险：

Please understand the following potential hazards during battery use and operation:

9.2.1 操作者在操作时可能会受到电击或者电弧的伤害。尽管人体对遭受直流电与交流电的反应不同，但是高于 60 伏的直流电压与交流电对人体的伤害是同样严重的，因此客户必须在操作中采取保守的姿势以避免电流的伤害。

The operator may be exposed to electric shock or arcing during operation. Although the human body reacts differently to direct current and alternating current, the DC voltage higher than 60 V is as severe as the damage caused by alternating current, so the operator should take a conservative actions in operation to avoid high voltage damage.

9.2.2 存在来自电池中的电解液的化学风险。

There is a chemical risk from the electrolyte in the battery.

10. 电芯示意图 Cell drawings

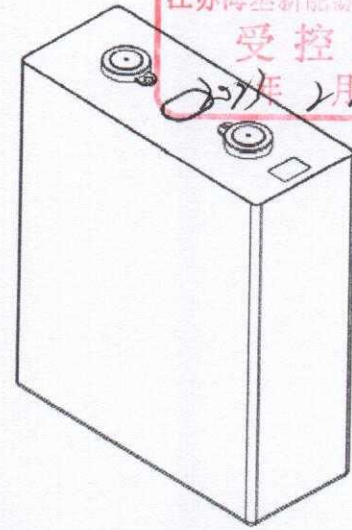
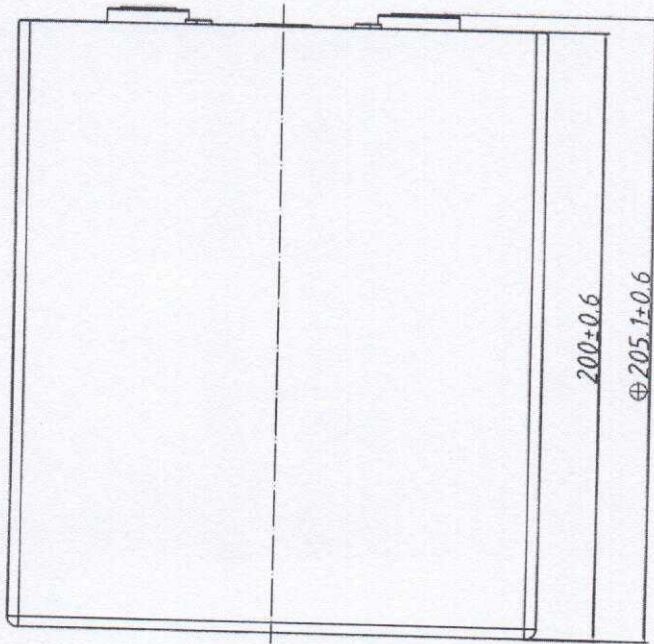
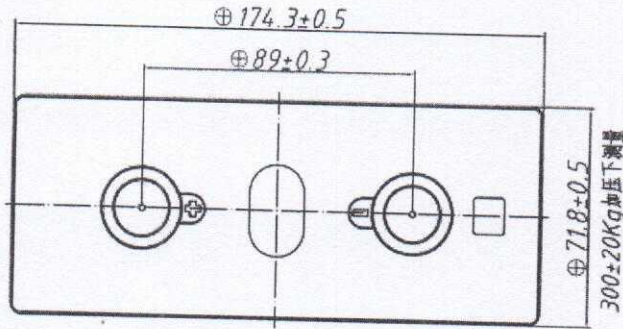

江苏海基新能源股份有限公司
受控文件
2017年 2月 7日

